

Enteral Data Sheet

Revision 3.1

Ref Doc: PSD0016		No.: ELDISO-XH2 & EISO-XXH2		Rev. 4
Product:	ISOSAF Home 2 Syringes		Application:	Enteral
Technical Qualification				
Raw Materials:	Barrel - Polypropylene		Plunger (2.5ml-100ml) - Polypropylene	
	Plunger (1ml) - HDPE		Lubricant- Silicone Oil	
	Gasket- Polyisoprene Rubber		Printing Ink – PPE/ PPO Ink Series	
Packing:	Primary - Medical Dialysis Paper, PP/PE Medical composite packaging film			
	Secondary - Hard Corrugated Paper			
	Tertiary - Double Corrugated Paper			
Regulatory:	Class I S&M – 1ml, 2.5ml & 100ml Class IIa – 5ml - 60ml			
Others:	Shelf Life – 5 years EO Sterilisation Latex free			
Products:				
Code:	Description:			
ELDISO-1H2	ISOSAF 1ml Low Dose Home 2 ENFit Syringe			
ELDISO-2.5H2	ISOSAF 2.5ml Low Dose Home 2 ENFit Syringe			
ELDISO-5H2	ISOSAF 5ml Low Dose Home 2 ENFit Syringe			
EISO-10H2	ISOSAF 10ml Home 2 ENFit Syringe			
EISO-20H2	ISOSAF 20ml Home 2 ENFit Syringe			
EISO-60H2	ISOSAF 60ml Home 2 ENFit Syringe			
EISO-100H2	ISOSAF 100ml Home 2 ENFit Syringe			
Intended Use:				
These medical devices are intended for use in combination with other devices that employ the ISO 80369-3 International Standard design for Small Bore Connectors. These devices are used as enteral syringes for medical use. This product is single patient use.				
Pictures:				
<i>Examples:</i>				
				

Packaging:		
Code:	Packing:	Units:
ELDISO-1H2	Primary – Blister 33mm (H) x 11.8mm (W) x 134mm (D)	1
	Secondary – Shelf Box 95mm (H) x 130mm (W) x 220mm (D)	100
	Tertiary – Shipper Carton 465mm (H) x 410mm (W) x 600mm (D)	3600
ELDISO-2.5H2	Primary – Blister 36mm (H) x 13.35mm (W) x 122mm (D)	1
	Secondary – Shelf Box 125mm (H) x 135mm (W) x 215mm (D)	100
	Tertiary – Shipper Carton 530mm (H) x 450mm (W) x 565mm (D)	3200
ELDISO-5H2	Primary – Blister 39.6mm (H) x 17.6mm (W) x 125mm (D)	1
	Secondary – Shelf Box 175mm (H) x 140mm (W) x 225mm (D)	100
	Tertiary – Shipper Carton 550mm (H) x 470mm (W) x 580mm (D)	2400
EISO-10H2	Primary – Blister 44mm (H) x 20.8mm (W) x 147mm (D)	1
	Secondary – Shelf Box 115mm (H) x 170mm (W) x 390mm (D)	100
	Tertiary – Shipper Carton 535mm (H) x 410mm (W) x 600mm (D)	1500
EISO-20H2	Primary – Blister 57mm (H) x 23.5mm (W) x 165mm (D)	1
	Secondary – Shelf Box 170mm (H) x 180mm (W) x 420mm (D)	100
	Tertiary – Shipper Carton 535mm (H) x 435mm (W) x 560mm (D)	900
EISO-60H2	Primary – Blister 67.5mm (H) x 36.5mm (W) x 205mm (D)	1
	Secondary – Shelf Box 175mm (H) x 225mm (W) x 370mm (D)	50
	Tertiary – Shipper Carton 378mm (H) x 385mm (W) x 470mm (D)	200
EISO-100H2	Primary – Blister 80mm (H) x 39.4mm (W) x 252mm (D)	1
	Secondary – Shelf Box 125mm (H) x 275mm (W) x 435mm (D)	30
	Tertiary – Shipper Carton 275mm (H) x 290mm (W) x 450mm (D)	60

Code:	GTIN Primary:	GTIN Secondary:	GTIN Tertiary:
ELDISO-1H2	05060590881590	05060590881606	05060590881613
ELDISO-2.5H2	05060590881620	05060590881637	05060590881644
ELDISO-5H2	05060590881651	05060590881668	05060590881675
EISO-10H2	05060590881682	05060590881699	05060590881705
EISO-20H2	05060590881712	05060590881729	05060590881736
EISO-60H2	05060590881743	05060590881750	05060590881767
EISO-100H2	05060590881774	05060590881781	05060590881798

Code:	Quantity per Pallet:	Pallet Dimensions:
ELDISO-1H2	28800	1200mm x 1000mm
ELDISO-2.5H2	25600	1200mm x 1000mm
ELDISO-5H2	19200	1200mm x 1000mm
EISO-10H2	12000	1200mm x 1000mm
EISO-20H2	7200	1200mm x 1000mm
EISO-60H2	3600	1200mm x 1000mm
EISO-100H2	1920	1200mm x 1000mm

Drawings:

THIS DRAWING IS CONFIDENTIAL AND THE PROPERTY OF THE COMPANY "GBUK Group" IT CANNOT BE GIVEN, COMMUNICATED OR COPIED WITHOUT OUR AUTHORIZATION

DIMENSIONS THE ON THE DRAWING NOT TO SCALE

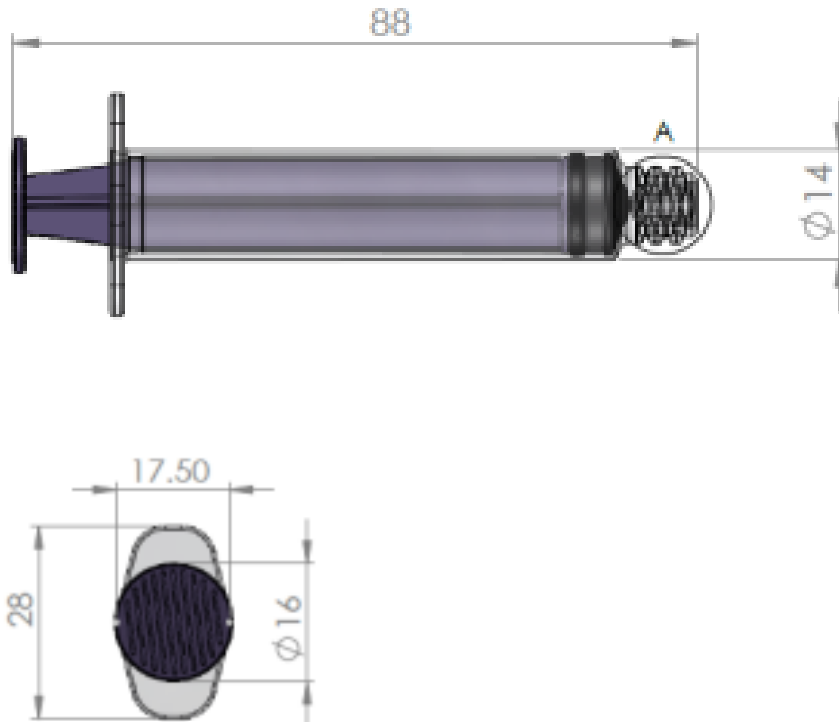

Description: Primary Artwork

Figure 1: ELDISO-1H2

*** Variations: ELDISO-2.5H2, ELDISO-5H2 ***

Figure 2: EISO-10H2

*** EISO-20H2, EISO-60H2, EISO-100H2 ***

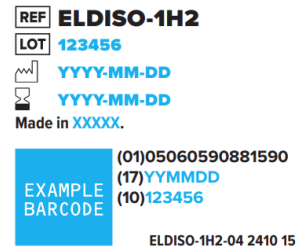

Figure 1

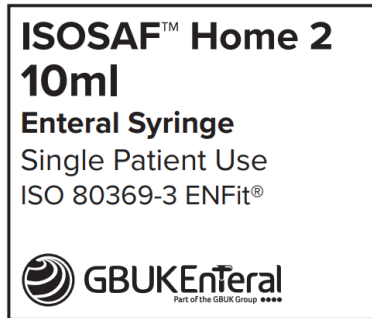

Figure 2

Description: Secondary Artwork

Figure 3: ELDISO-1H2

*** Variations: ELDISO-2.5H2, ELDISO-5H2 ***

Figure 4: EISO-10H2

*** EISO-20H2, EISO-60H2, EISO-100H2 ***



Figure 3



Figure 4

Description: Tertiary Artwork

Figure 5: ELDISO-1H2

*** Variations: ELDISO-2.5H2, ELDISO-5H2 ***

Figure 6: EISO-10H2

*** EISO-20H2, EISO-60H2, EISO-100H2 ***

Figure 5



Figure 6

Modified by:	Name: Nicola Neal	Signature: 	Date: 28-Feb-25 I have reviewed this document 28-Feb-25 11:08:40 AM GMT
Reviewed by:	Name: Aleksandra Malek	Signature: 	Date: 28-Feb-25 I approve this document 28-Feb-25 11:21:55 AM GMT
 GBUK Enteral is a trading name of GBUK Enteral Ltd. GBUK Enteral Ltd. Is part of GBUK Group Ltd.		E58BAC08B3C6162B7AD3748E97B34C7 GBUK Enteral Woodland House Blackwood Hall Business Park North Duffield, North Yorkshire YO8 5DD, UK TEL: +44 (0) 1757 282 945 https://www.gbukgroup.com/ https://www.gbukgroup.com/brands/gbuk-ental/	